



Knowledge Base

powered by  ALARM.COM

Alarm.com Premium Video Doorbell Camera (ADC-VDB775) - Installation Guide

Pre-installation checklist

- ADC-VDB775 with included accessories
- Wired doorbell transformer 16-24 VAC, 10-40 VA or power supply (minimum 15 VDC 8 W); specifications are often written directly on the power source
- Wired compatible mechanical chime or digital chime
- Wi-Fi (2.4 or 5 GHz) connection to broadband Internet (Cable, DSL, or Fiber Optic)
- A computer, tablet, or smartphone with Wi-Fi is required

There are three options for connecting the ADC-VDB775 to the Wi-Fi network:

- Bluetooth Enrollment (BLE) mode
- Access Point (AP) mode
- Wi-Fi Protected Setup (WPS) mode

In the box

Note: The ADC-VDB775 also includes wall anchors (x2) & ST3.5 x 22mm screws (x2)

[ADC-VDB775 camera](#) [ADC-VDB775 wallplate](#) [Mechanical Chime Dongle \(ADC-VDBA-MCD\)](#) [Installation card with scannable QR code](#)

ADC-VDB775 camera

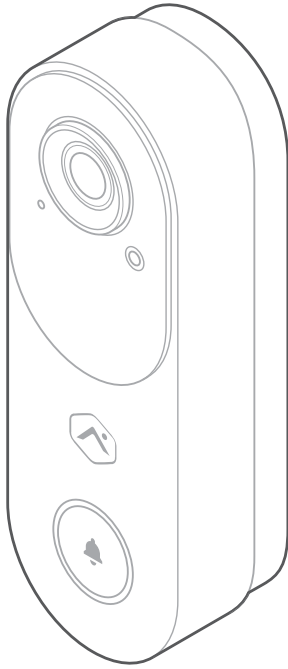

ADC-VDB775 wallplate

Note: Wire terminal screws and wallplate removal tool also included

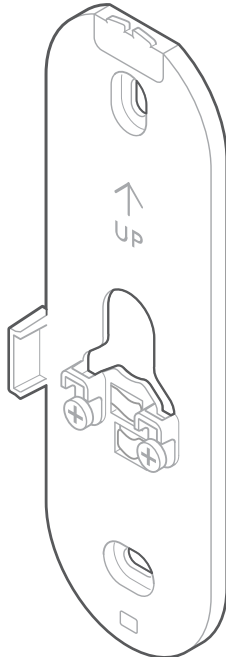

Mechanical Chime Dongle (ADC-VDBA-MCD)

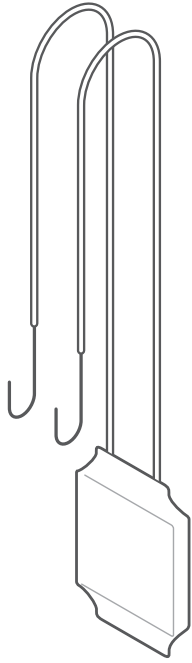

Installation card with scannable QR code

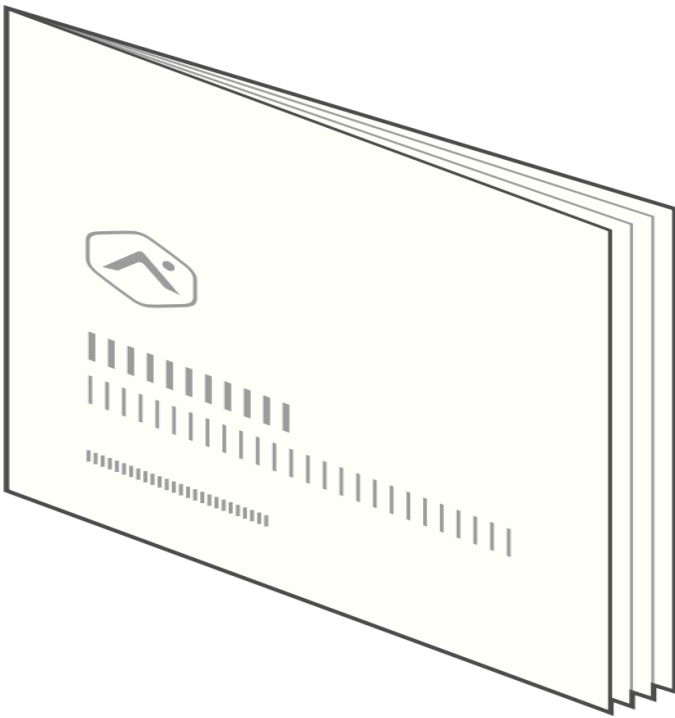

Install the ADC-VDB775

For more information about general installation guidelines, see [Video Installation Best Practices](#).

Physical installation:

1. Turn off power to the doorbell circuit (transformer). The recommended transformer rating is 16-24 VAC, 10-40 VA.
2. Remove any existing power module from the in-home chime belonging to the video doorbell that is being replaced.
3. Verify that the chime wire terminals are connected to one wire run from the transformer and one wire run from the doorbell.
 - Select the in-home wired chime type below for installation steps.
[Mechanical chime](#) [Digital chime](#) [No wired chime](#)

Mechanical chime

Connect the Mechanical Chime Dongle to the chime by connecting one wire to each of the terminals (i.e., *FRONT* and *TRANS* or *REAR* and *TRANS*), leaving the existing wires in place. Polarity does not matter.

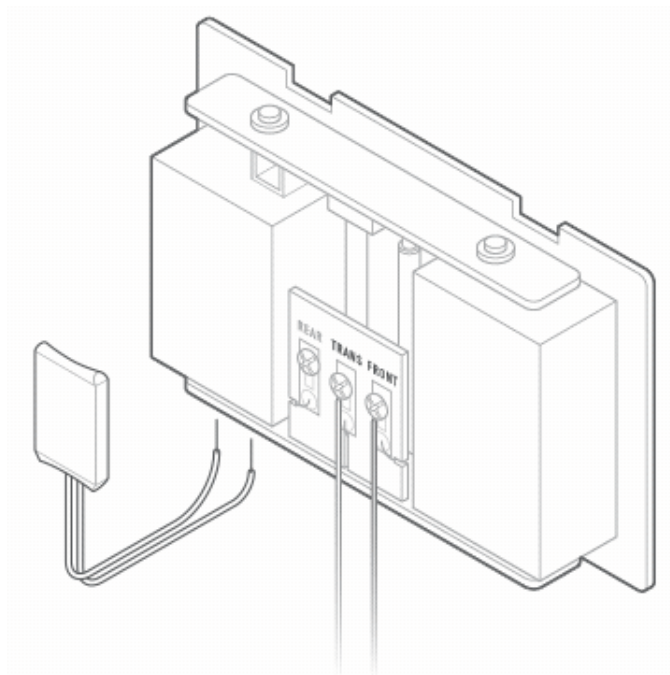

Digital chime

Connect the ADC-VDB775 Power Module to the chime by connecting one wire to each of the terminals (leaving the existing wires in place).

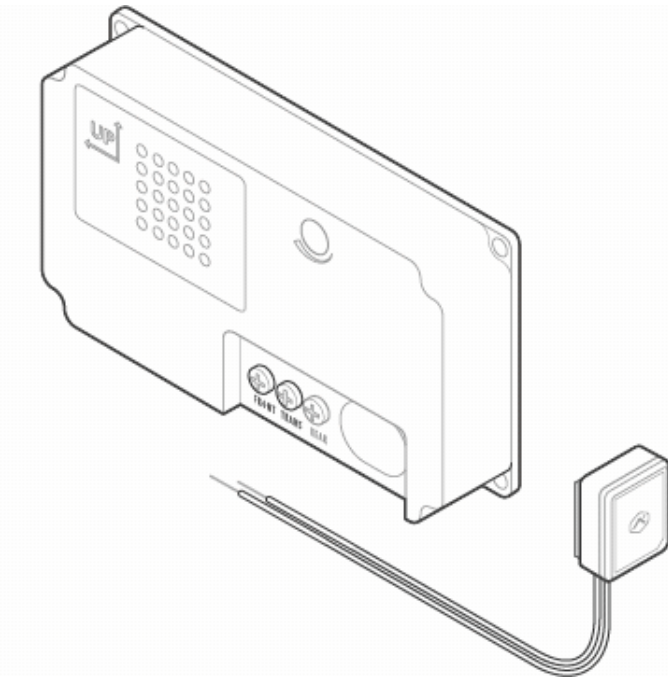

No wired chime

Verify that the power source (AC or DC) meets the product requirements, and wire directly (polarity does not matter) to the ADC-VDB775.

4. Remove the existing doorbell from the wall and disconnect the wires. Secure the wires so that they can be connected in a later step (you can tape them to the wall so they don't fall back into the wall).

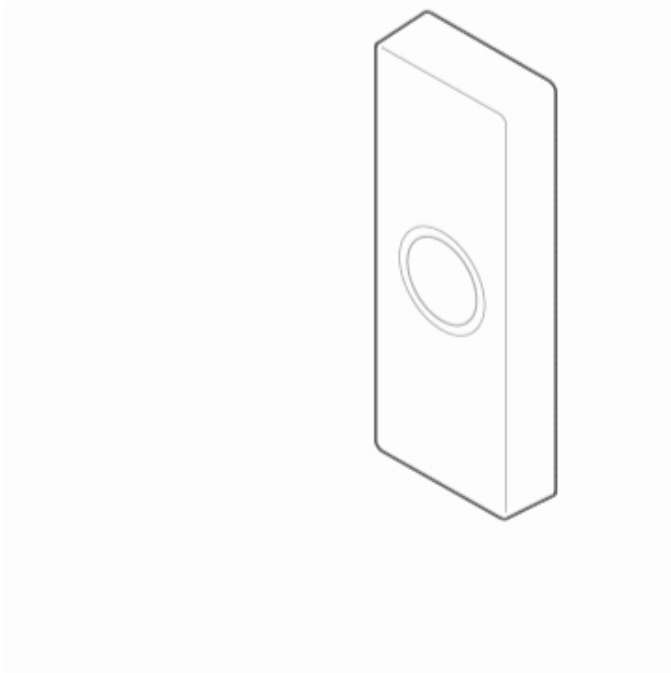

5. Verify the Video Doorbell installation height is less than 2 meters (6' 7") from floor level and in a vertical orientation.
6. If using an optional wedge, thread the wires at the doorbell through the center of the wedge, making sure that the flat side faces the wall. Then mount the wedge to the surface using the provided screws/anchors.

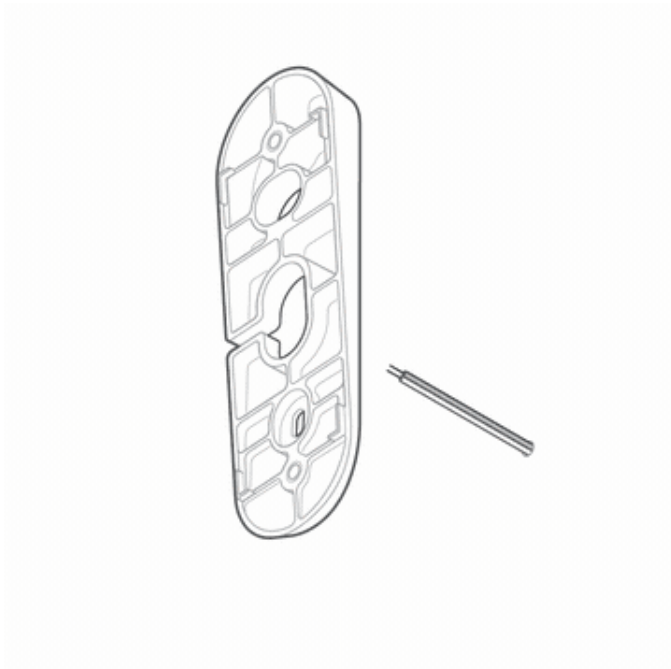

7. Thread doorbell wires through wallplate, making sure to thread wires underneath plastic bridges of wallplate leading to screw terminals, and secure to wallplate screw terminals.

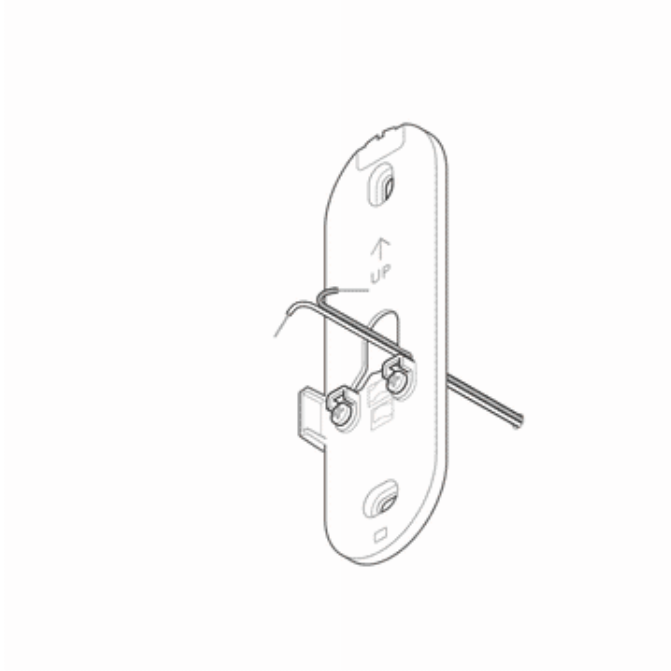

Important: Minimize the length of excess wire leads protruding from the area surrounding the screw terminals. Excess wire can interfere with the assembly to the ADC-VDB775 and may result in the device not powering on.

8. Determine whether to secure the wallplate to the optional wedge or mount it directly to the surface.
 - If using an optional wedge, secure the wallplate to the mounted wedge using the two machine screws provided with the Wedge Mount Kit.

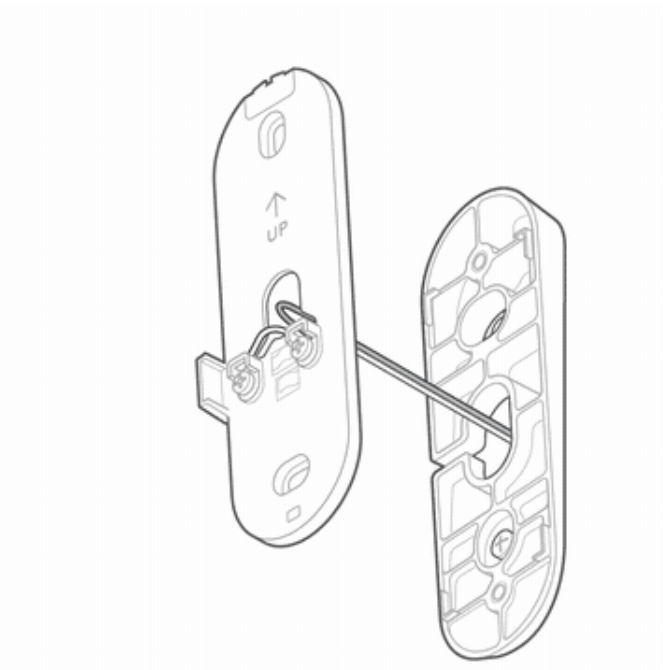

- If not using an optional wedge, mount the wallplate to the surface with the provided screws/anchors.

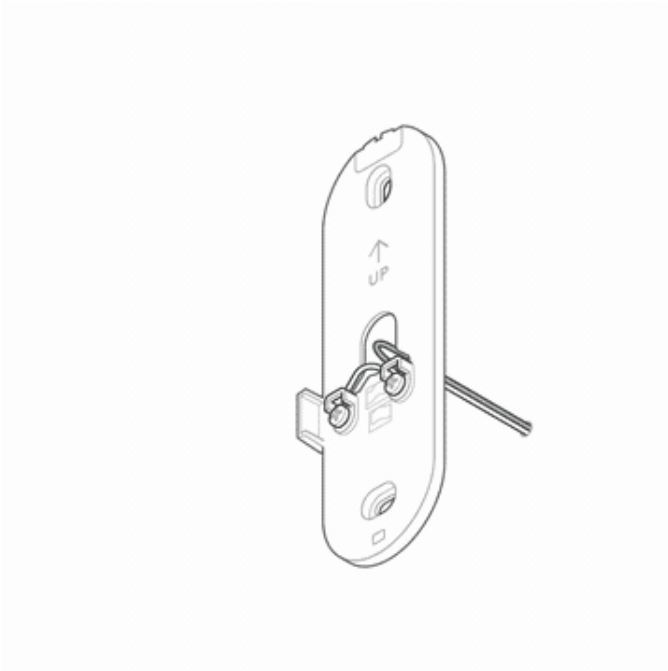

9. Connect ADC-VDB775 device to wallplate by first securing/latching the top edge, then pushing the device into the wallplate until it clicks.

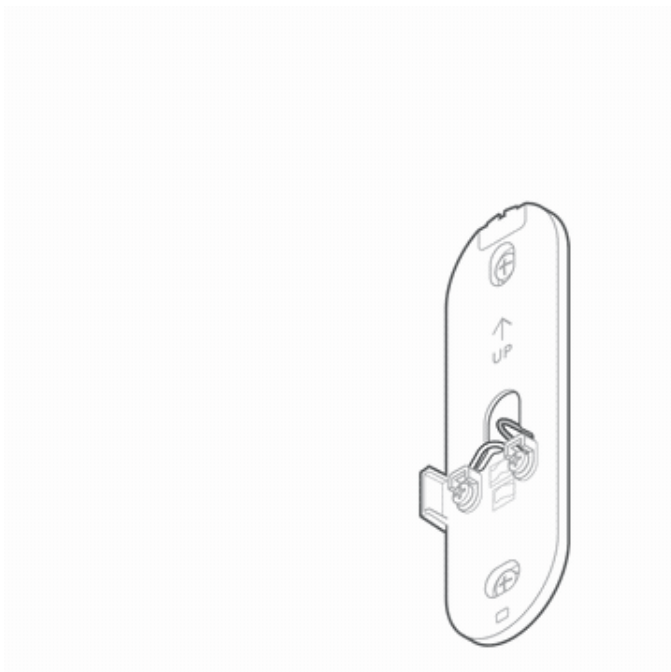

10. Restore power to the doorbell circuit (transformer).

Connect the ADC-VDB775 to the Wi-Fi network

The ADC-VDB775 can be connected to the Wi-Fi network using Bluetooth Enrollment (BLE) mode, Access Point (AP) mode, or Wi-Fi Protected Setup (WPS).

Note: An installation tutorial can also be found on the enrollment page of the MobileTech app, Customer app, or Customer website to walk through these steps.

[BLE mode \(recommended\)](#) [AP Mode](#) [WPS Mode](#)

BLE mode (recommended)

Note: This method will also enroll the device to the customer's account as part of the process.

To ensure a sufficient Wi-Fi signal, complete the following steps with the camera near its final location but prior to mounting.

1. Connect the camera to power. Verify the device powers on and the LED begins to blink white.
 - If it does not blink white after two minutes, press and hold the doorbell button and release when the LED begins to blink white (about 30 seconds).
2. On a Bluetooth-enabled mobile device, log in to the Customer app or MobileTech app and complete the following step to add the video device to the customer's account.

To connect devices via BLE mode using the Customer app: ^

1. Log in to the Customer app.
2. Tap **More**.
3. Tap **Add Device**.
4. Tap **Video**.
5. Scroll to find the device or use the *Find Device* search bar to enter the model number, and then tap to select the device to add.
6. Enter a *Device Name*, then tap **Next**.
7. Power on the device and verify the LED light is flashing white, then tap **Next**.
 - If it is not flashing white, press and hold the button until the status LED starts blinking white. This may take several seconds.
 - Tap **Troubleshoot** to learn more about how to get the device to that state.
8. If Bluetooth is not enabled on your mobile device, approve the Bluetooth permission request when prompted, and then tap **Next**.
9. Bring your mobile device close to the device being enrolled, then tap **Scan**.
10. Allow time for your mobile device to scan for devices in the area.
11. Select the device to set up. Verify the selected device's MAC address matches the MAC address on the device being enrolled, then tap **Connect**.
12. Keep your phone near the device while it connects.
13. Once your phone is connected to the device, tap to select the Wi-Fi network. Either:

- Select a known network in *My Wi-Fi Networks*, or
 - Select a new network in *Other Networks*, enter the password for the Wi-Fi network, and then tap **Connect**.
14. Allow a few minutes for the device to connect to the network.
 15. Once the device connects to the Wi-Fi network, the device continues to complete the install on the customer's account. Once the installation is complete, verify the video device works properly.

To connect devices via BLE mode using the MobileTech app: ^

1. Log in to the MobileTech app.
2. Find the customer account.
3. Tap **Add Device**.
4. Tap **Video**.
5. If Bluetooth is not enabled on your mobile device, approve the Bluetooth permission request when prompted, and then tap **Next**.
 - You may need to enable Bluetooth in your phone settings.
6. Once Bluetooth is enabled, find the device to enroll by verifying the MAC address and then tap to select the device to start connecting to it.
7. Keep your phone near the device while it connects.
8. Once the mobile device connects to the device, enter a *Device Name*, then tap **Next**.
9. Once your phone is connected to the device, tap to select the Wi-Fi network. Either:
 - Select a known network in *My Wi-Fi Networks*, or
 - Select a new network in *Other Networks*, enter the password for the Wi-Fi network, and then tap **Connect**.
10. Allow a few minutes for the device to connect to the network.
11. Once the device connects to the Wi-Fi network, the device continues to complete the install on the customer's account. Once the installation is complete, verify the video device works properly.

AP Mode

1. Verify that the device powers on (flashing red LED) and then goes to AP mode (flashing white LED).
 - If the LED is not white after two minutes, press and hold the doorbell button and release when the LED begins to blink white (about 30 seconds).
2. On an Internet-enabled device, connect to the Wi-Fi network ADC-VDB775 (XX:XX:XX) where XX:XX:XX is the last six characters of the ADC-VDB775's MAC address, which is located on the device or packaging.
3. On the same device, open a web browser and enter <http://vdb775install.com> or **192.168.1.1** in the URL field. Follow the on-screen instructions to add the ADC-VDB775 to the Wi-Fi network. The LED may briefly turn red before blinking green. The LED will be solid green when the connection is complete.
4. Once the LED is solid green, enroll the device to the account using the steps in [Enroll the VDB775 to the account](#).

WPS Mode

1. Verify that device boots (flashing red LED) to AP mode (flashing white LED).
2. Press and hold the doorbell button and release when the LED begins to blink blue for WPS mode (about 35 seconds).
3. Activate WPS mode on the router. Consult your router's user guide for more information
4. The device will begin to connect to the Wi-Fi network. The LED will be solid green when the connection is complete.
5. Once the LED is solid green, enroll the device to the account using the steps in [Enroll the VDB775 to the account](#).

Enroll the VDB775 to the account

The ADC-VDB775 can be enrolled to a customer account using the MobileTech app, Customer website, or Customer app.

[MobileTech app](#) [Customer website](#)[Customer app](#)

MobileTech app

1. Log in to the MobileTech app.
2. Find the customer account.
3. Tap + **Add Device**.
4. Tap **Video**.
5. In *Enter MAC Address*, enter the MAC address, which is located on the device or packaging.
6. Tap **Add**.
7. Enter a name for the device, then tap **Continue**.
8. Follow the on-screen instructions. An installation progress bar displays on the screen.

Once the installation is complete, test the device to verify it is working as expected.

Customer website

1. Navigate to the *Video Device Setup* page by entering the following URL using a web browser: **www.alarm.com/addcamera**. The customer's username and password for the account are required to log in.
 - If the installation tutorial was used, it automatically navigates to this page after completing the tutorial.
2. Enter the MAC address, which is located on the device or packaging, and then click **Find**.
3. Enter a name for the device, then click **Install**.
4. Follow the on-screen instructions to finish adding the camera. An installation progress bar displays on the screen.

Once the installation is complete, test the device to verify it is working as expected.





Customer app

1. Log in to the Customer app. You will need the username and password of the account to log in.

2. Tap .
3. Tap **Add Device**.
4. Tap **Doorbell Camera**.
 - If the device LED is not solid green, tap **ADC-VDB775** for the installation tutorial. If the device is already connected to Wi-Fi and has a solid green LED, continue to the next step.
5. Tap **Enter MAC Address**, then enter the camera's MAC address, which is located on the device or packaging.
6. Tap **Install** for the camera on the *Device Found* page.
7. Enter a device name, then tap **Next**.
8. Follow the on-screen instructions to finish adding the camera. The installation progress displays on the screen.

Once the installation is complete, test the device to verify it is working as expected.

LED status guide

| LED pattern | Description |
|---|--------------------------|
| Off  | Power off |
| Solid green  | Connected to Alarm.com |
| Blinking green  | Local network connection |
| Blinking red  | Power on, camera booting |

LED pattern

Description

Solid red



No local or internet connection

Blinking white



Wi-Fi Access Point mode (press and hold the reset button for 30-35 seconds)

Blinking blue



WPS mode (press and hold button for 35-40 seconds)

Blinking yellow



Power cycling (press and hold button for 40-45 seconds)

Blinking red and green



Camera resetting to factory default (press and hold button for 45-50 seconds)

Blinking blue and green



Firmware updating

Troubleshooting

1. If you have issues connecting the camera to the account, power cycle the camera and try again.
2. If issues persist, reset the camera to factory defaults. Press and hold the Doorbell Button until the LED is flashing green and red (about 45 seconds), then release the button. The camera will reboot to factory default.

If the camera was previously installed on a different Alarm.com account, it will need to be deleted before it can be

https://answers.alarm.com/Partner/Installation_and_Troubleshooting/Video_Devices/Alarm.com_Premium_Video_Doorbell_C...

Updated: Fri, 16 Jan 2026 19:16:30 GMT

installed again.

Caution: Prolonged exposure to sunlight in extreme conditions may impact the camera's performance.

Regulatory statements

Operating Temperature: -58°F - 122°F (-50°C - 50°C)

Ingress Protection: IP65

FCC statements

FCC Part 15 Statement

Note: This equipment has been tested and found to comply with the limits for a Class B digital device, pursuant to part 15 of the FCC Rules. These limits are designed to provide reasonable protection against harmful interference in a residential installation. This equipment generates, uses and can radiate radio frequency energy and, if not installed and used in accordance with the instructions, may cause harmful interference to radio communications. However, there is no guarantee that interference will not occur in a particular installation.

If this equipment does cause harmful interference to radio or television reception, which can be determined by turning the equipment off and on, the user is encouraged to try to correct the interference by one or more of the following measures:

- Reorient or relocate the receiving antenna.
- Increase the separation between the equipment and receiver.
- Connect the equipment into an outlet on a circuit different from that to which the receiver is connected.
- Consult the dealer or an experienced radio/TV technician for help.
- Changes or modifications not expressly approved by the party responsible for compliance could void the user's authority to operate the equipment.

FCC ID

FCC ID: YL6-143VDB775

ISED Statements

Condition

This device contains license-exempt transmitter(s)/receiver(s) that comply with Innovation, Science and Economic Development Canada's licence-exempt RSS(s). Operation is subject to the following two conditions:

1. This device may not cause interference.

2. This device must accept any interference, including interference that may cause undesired operation of the device.

The device operating in the 5150–5250 MHz band is intended for indoor use only.

Cet appareil contient des émetteurs/récepteurs sans licence qui sont conformes aux RSS sans licence d'Innovation, Sciences et Développement économique Canada. L'exploitation est soumise aux deux conditions suivantes :

1. Cet appareil ne doit pas provoquer d'interférences.
2. Cet appareil doit accepter toute interférence, y compris les interférences susceptibles de provoquer un fonctionnement indésirable de l'appareil.

Le dispositif fonctionnant dans la bande de fréquences 5150–5250 MHz est destiné uniquement à une utilisation intérieure.

RF Exposure

This equipment complies with FCC and ISED radiation exposure limits set forth for an uncontrolled environment. This equipment should be installed and operated with a minimum distance of 20cm between the equipment and your body. This device and its antenna(s) must not be co-located or operating in conjunction with any other antenna or transmitter. Please contact intsupport@alarm.com for more information on Canadian RF exposure compliance.

RF Exposure

Cet appareil est conforme aux limites d'exposition aux radiofréquences établies par la FCC et l'ISED pour un environnement non contrôlé. Cet appareil doit être installé et utilisé à une distance minimale de 20 centimètres entre l'appareil et votre corps. Cet appareil et son ou ses antennes ne doivent pas être situés ou fonctionner en conjonction avec une autre antenne ou un autre émetteur. Veuillez communiquer avec intsupport@alarm.com pour obtenir plus d'information sur la conformité aux exigences canadiennes en matière d'exposition aux radiofréquences.

IC ID

IC: 9111A-143VDB775